Travail de fin d'études et stage[BR]- Travail de fin d'études : Conception du système de mesure de la bande analytique de la ligne de tri "PickIt"[BR]- Stage d'insertion professionnelle : Laboratoire Gemme (ArGenCo)

Auteur : Senger, Antoine

Promoteur(s) : Bruls, Olivier

Faculté : Faculté des Sciences appliquées

Diplôme : Master en ingénieur civil mécanicien, à finalité spécialisée en technologies durables en automobile

Année académique : 2023-2024

URI/URL : <http://hdl.handle.net/2268.2/19593>

Avertissement à l'attention des usagers :

Tous les documents placés en accès ouvert sur le site le site MatheO sont protégés par le droit d'auteur. Conformément aux principes énoncés par la "Budapest Open Access Initiative"(BOAI, 2002), l'utilisateur du site peut lire, télécharger, copier, transmettre, imprimer, chercher ou faire un lien vers le texte intégral de ces documents, les disséquer pour les indexer, s'en servir de données pour un logiciel, ou s'en servir à toute autre fin légale (ou prévue par la réglementation relative au droit d'auteur). Toute utilisation du document à des fins commerciales est strictement interdite.

Par ailleurs, l'utilisateur s'engage à respecter les droits moraux de l'auteur, principalement le droit à l'intégrité de l'oeuvre et le droit de paternité et ce dans toute utilisation que l'utilisateur entreprend. Ainsi, à titre d'exemple, lorsqu'il reproduira un document par extrait ou dans son intégralité, l'utilisateur citera de manière complète les sources telles que mentionnées ci-dessus. Toute utilisation non explicitement autorisée ci-avant (telle que par exemple, la modification du document ou son résumé) nécessite l'autorisation préalable et expresse des auteurs ou de leurs ayants droit.

ROBOTICS

Product specification

IRB 360



Trace back information:
Workspace 21C version a3
Checked in 2021-09-23
Skribenta version 5.4.005

Product specification

IRB 360-1/1130

IRB 360-3/1130

IRB 360-8/1130

IRB 360-1/1600

IRB 360-6/1600

IRC5

Document ID: 3HAC029963-001

Revision: Z

The information in this manual is subject to change without notice and should not be construed as a commitment by ABB. ABB assumes no responsibility for any errors that may appear in this manual.

Except as may be expressly stated anywhere in this manual, nothing herein shall be construed as any kind of guarantee or warranty by ABB for losses, damage to persons or property, fitness for a specific purpose or the like.

In no event shall ABB be liable for incidental or consequential damages arising from use of this manual and products described herein.

This manual and parts thereof must not be reproduced or copied without ABB's written permission.

Keep for future reference.

Additional copies of this manual may be obtained from ABB.

Original instructions.

© Copyright 2004-2021 ABB. All rights reserved.
Specifications subject to change without notice.

Table of contents

Overview of this specification	7
1 Description	11
1.1 Structure	11
1.1.1 Introduction to structure	11
1.1.2 Different robot version	13
1.1.3 Definition of version designation	14
1.2 Safety standards	16
1.2.1 Applicable standards	16
1.3 Installation	18
1.3.1 Introduction to installation	18
1.3.2 Operating requirements	19
1.3.3 Mounting the manipulator	20
1.4 Load diagrams	24
1.4.1 Introduction to load diagrams	24
1.4.2 Load diagrams	25
1.4.3 Hose set mounted on the manipulator arms	32
1.4.4 Mechanical interface	33
1.5 Maintenance and troubleshooting	36
1.5.1 Introduction to maintenance and trouble shooting	36
1.6 Robot motion	37
1.6.1 Introduction to robot motion	37
1.6.2 Performance according to ISO 9283	39
1.6.3 Acceleration	41
1.7 Typical cycle times	42
1.7.1 Introduction to typical cycle times	42
2 Specification of variants and options	43
2.1 Introduction to variants and options	43
2.2 Manipulator	44
2.3 Floor cables	47
2.4 Process	48
2.5 User documentation	49
3 Accessories	51
3.1 Introduction to accessories	51
Index	53

This page is intentionally left blank

Overview of this specification

About this product specification

This product specification describes the performance of the manipulator or a complete family of manipulators in terms of:

- The structure and dimensional prints
- The fulfilment of standards, safety, and operating equipment
- The load diagrams, mounting or extra equipment, the motion, and the robot reach
- The specification of available variants and options

The specification covers the manipulator using the IRC5 controller.

Usage

Product specifications are used to find data and performance about the product, for example to decide which product to buy. How to handle the product is described in the product manual.

The specification is intended for:

- Product managers and product personnel
- Sales and marketing personnel
- Order and customer service personnel

References

Reference	Document ID
<i>Product specification - Controller IRC5 or Product specification - Product.ProductName</i> IRC5 with main computer DSQC1000.	3HAC047400-001 (IRC5) or <i>Document.ID-1</i> (MC)
<i>Product specification - Controller software IRC5 or Product specification - Controller software OmniCore</i> IRC5 with main computer DSQC1000 and RobotWare 6.	3HAC050945-001 (RobotWare 6) or 3HAC065035-001 (RobotWare 7)
<i>Product specification - PickMaster 3</i>	3HAC041347-001
<i>Product manual - IRB 360</i>	3HAC030005-001
<i>Product specification - Robot user documentation, IRC5 with RobotWare 6</i>	3HAC052355-001



Tip

All documents can be found via myABB Business Portal, www.abb.com/myABB.

Revisions

Revision	Description
-	New Product specification
A	Figure for hole configuration updated

Continues on next page

Overview of this specification

Continued

Revision	Description
B	Explanation of ISO values (new figure and table) User documentation on DVD
C	Option Clean Room added General update for 9.1 release
D	New variant added
E	General corrections
F	Text for Standards updated
G	Information regarding performance at 1-phase power supply
H	Load diagram for IRB 360-3/1130 adjusted and minor corrections.
J	<ul style="list-style-type: none"> • Table for ambient temperature adjusted • ISO data for IRB 360-1/1600 added
K	<ul style="list-style-type: none"> • Machinery directive updated • Variant IRB 360-1/800 removed • General corrections/update
L	<ul style="list-style-type: none"> • IRB 360-1/800 added again • New variant IRB 360-8/1130 added
M	<ul style="list-style-type: none"> • IRB 360-6/1600 added • Minor general corrections/update
N	<ul style="list-style-type: none"> • Text for ISO test adjusted
P	<ul style="list-style-type: none"> • Minor corrections
Q	<ul style="list-style-type: none"> • Description of test cycle changed • Text regarding detection of collisions adjusted
R	<ul style="list-style-type: none"> • Values for Backlash axis 4 are changed, and text deleted.
S	<ul style="list-style-type: none"> • Updated list of applicable standards.
T	Published in release 18.1. The following updates are done in this revision: <ul style="list-style-type: none"> • Dimension of Interface without axis 4 changed. • IRB360-1/800 new cycle time data added.
U	Published in release 18.2. The following updates are done in this revision: <ul style="list-style-type: none"> • Updated the detergents that stainless version of the wash down robot is against.
V	Published in release R19B The following updates are done in this revision: <ul style="list-style-type: none"> • Option 174-2 Medium phased out. • Option 218-9 Vacuum system phased out. • Variant 435-82 IRB 360-1/800 phased out.
W	Published in release R20A The following updates are done in this revision: <ul style="list-style-type: none"> • Remove the IRB 360-1/1600 from 3-axis option.
X	Published in release R20B The following updates are done in this revision: <ul style="list-style-type: none"> • Remove the information of standard vacuum systems.
Y	Published in release R20D The following updates are done in this revision: <ul style="list-style-type: none"> • Warranty section updated

Continues on next page

Revision	Description
Z	Published in release 21C. The following updates are done in this revision: <ul style="list-style-type: none"><li data-bbox="746 367 1257 398">• Text regarding fastener quality is updated.<li data-bbox="746 400 954 432">• Minor updates.

This page is intentionally left blank

1 Description

1.1 Structure

1.1.1 Introduction to structure

Robot family

The IRB 360 is ABB Robotics' latest generation of high performance industrial robots. Based on the famous IRB 340 robot family in a modular design. It is specially designed for industries with a great need for flexible automation, such as pick and place operations and assembly. The IRB 360 is extremely powerful with an acceleration of up to 10 g's, and a handling capacity of up to 8 kg. Thanks to optimized drive-chains and ABB's patented QuickMove™ functions it is the fastest robot in its class, up to 200 picks per minute (defined by cycle and load).

Operating system

The robot is equipped with the IRC5 controller and robot control software, RobotWare. RobotWare supports every aspect of the robot system, such as motion control, development and execution of application programs, communication etc. see *Product specification - Controller IRC5* or *Product specification - Product.ProductName*.

Safety

Safety standards valid for complete robot, manipulator and controller.

Additional functionality

For additional functionality, the robot can be equipped with optional software for application support - communication features - network communication - and advanced functions such as multi-tasking, sensor control, etc. For a complete description on optional software, see *Product specification - Controller software IRC5* or *Product specification - Controller software OmniCore*.

PickMaster is a specific application software for vision guided picking. It is providing a task-oriented programming and executions of fast pick and place operations, see *Product specification - PickMaster 3*.

Clean room robots



xx0900000435

The clean room robots are classified for room class 5 according to ISO 14644-1. For options not selectable together with Clean Room, see [Specification of variants and options on page 43](#).

Continues on next page

1 Description

1.1.1 Introduction to structure

Continued

Stainless Wash Down Robots

The stainless version of the wash down robot has a stainless steel base, and all other main parts, such as delta plate, arm system and telescopic shaft made of stainless steel/composites.

The stainless version is verified against the following detergents:

- Strongly alkaline: Topaz MD4 (3%)
 - Strongly alkaline with chloride: Topaz CL2 (3%)
 - Strongly acid (for removing calcium oxide): Topaz AC3 (3%)
 - Acid (for disinfection): P3-topactive DES (1%)
-

Washdown statement

All components for Stainless WashDown protection class have been found to comply with USDA/FDA, Code of Federal Regulations Title 21 regarding choice of material, material behavior, and sanitary operations, as per 31 December 2007. Changes in the USDA/FDA regulations will be incorporated in the specification when appropriate. (Relevant chapters of CFR are part 100-199). The intended use is incidental food contact. Any gripper to be used must be investigated separately.

Manipulator axes

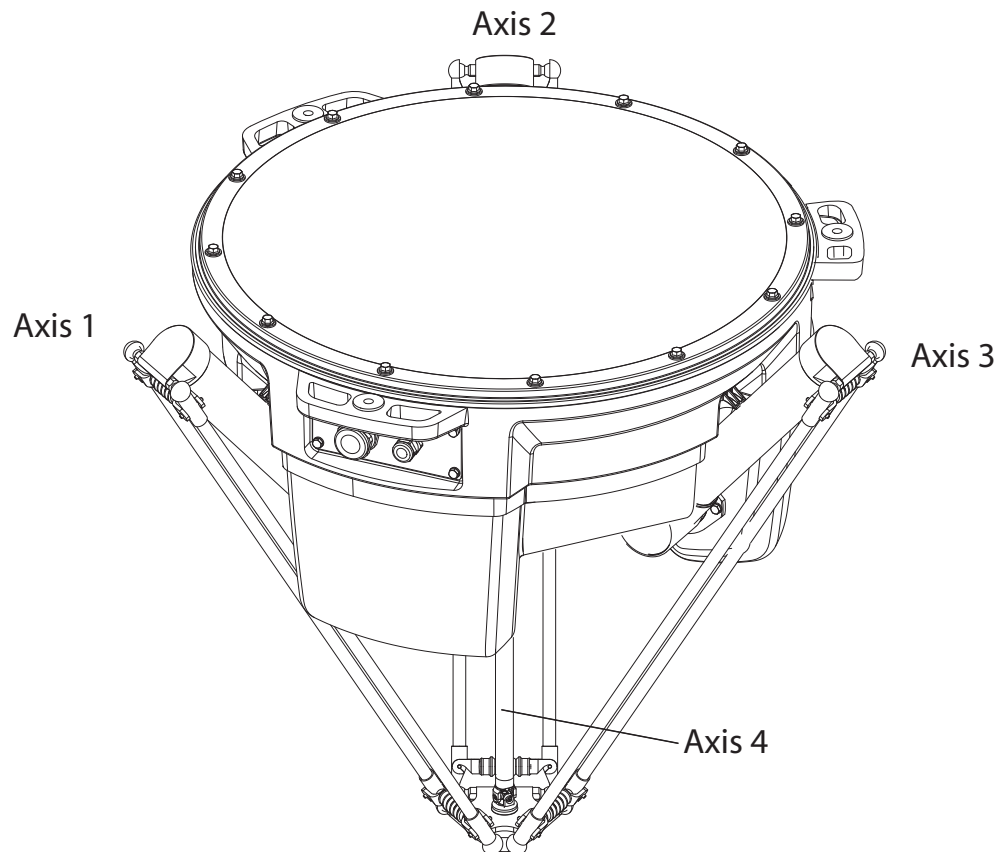

xx0900000412

1.1.2 Different robot version**Robot types**

The following different standard robot types are available:

Robot type	Handling capacity (kg)
IRB 360-1/1130	1 kg
IRB 360-3/1130	3 kg
IRB 360-8/1130	8 kg
IRB 360-1/1600	1 kg
IRB 360-6/1600	6 kg

1 Description

1.1.3 Definition of version designation

1.1.3 Definition of version designation

Weight

Manipulator	Weight
Standard Wash Down	120 kg
Stainless WashDown	145 kg

Other technical data

Data	Description	Note
Airborne noise level	The sound pressure level outside the working space	< 70 dB (A) Leq (acc. to Machinery directive 2006/42/EG)

Power consumption at max load

Type of movement	IRB 360/1
Typical pick - and - place cycle with 1 kg payload	0.477 kW

Continues on next page

IRB 360-1, IRB 360-3, 360-8, 360-1/800, IRB 360-1/1600 and IRB 360-6/1600

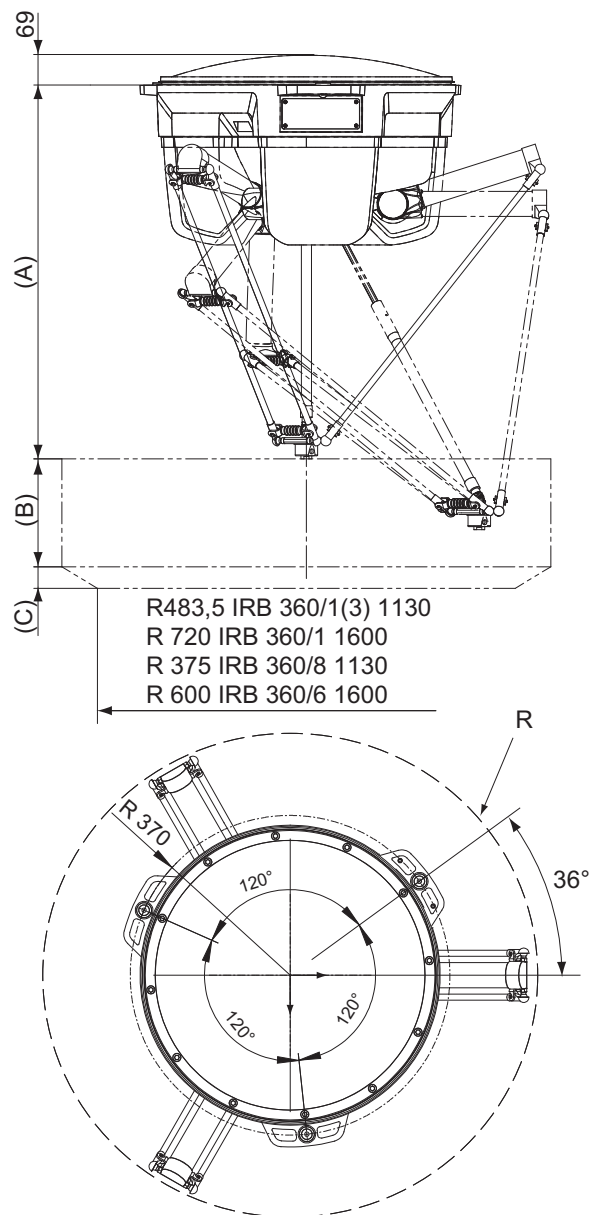

xx0900000411

Robot variant	A	B	C	R
IRB 360-1/800	960	200	-	400
IRB 360-1/1130	865	250	50	565
IRB 360-3/1130	865	250	50	565
IRB 360-8/1130	892	250	100	565
IRB 360-1/1600	1112	300	50	800
IRB 360-6/1600	1107.5	305	155	800

1 Description

1.2.1 Applicable standards

1.2 Safety standards

1.2.1 Applicable standards



Note

The listed standards are valid at the time of the release of this document. Phased out or replaced standards are removed from the list when needed.

General

The product is designed in accordance with ISO 10218-1:2011, Robots for industrial environments - Safety requirements -Part 1 Robots, and applicable parts in the normative references, as referred to from ISO 10218-1:2011. In case of deviations from ISO 10218-1:2011, these are listed in the declaration of incorporation which is part of the product delivery.

Normative standards as referred to from ISO 10218-1

Standard	Description
ISO 9283:1998	Manipulating industrial robots - Performance criteria and related test methods
ISO 10218-2	Robots and robotic devices - Safety requirements for industrial robots - Part 2: Robot systems and integration
ISO 12100	Safety of machinery - General principles for design - Risk assessment and risk reduction
ISO 13849-1:2006	Safety of machinery - Safety related parts of control systems - Part 1: General principles for design
ISO 13850	Safety of machinery - Emergency stop - Principles for design
IEC 60204-1:2005	Safety of machinery - Electrical equipment of machines - Part 1: General requirements
IEC 62061:2005	Safety of machinery - Functional safety of safety-related electrical, electronic and programmable electronic control systems

Region specific standards and regulations

Standard	Description
ANSI/RIA R15.06	Safety requirements for industrial robots and robot systems
ANSI/UL 1740	Safety standard for robots and robotic equipment
CAN/CSA Z 434-14	Industrial robots and robot Systems - General safety requirements

Other standards used in design

Standard	Description
ISO 9787:2013	Robots and robotic devices -- Coordinate systems and motion nomenclatures
IEC 61000-6-2	Electromagnetic compatibility (EMC) – Part 6-2: Generic standards – Immunity standard for industrial environments

Continues on next page

1 Description

1.2.1 Applicable standards

Continued

Standard	Description
IEC 61000-6-4 (option 129-1)	Electromagnetic compatibility (EMC) – Part 6-4: Generic standards – Emission standard for industrial environments
ISO 13732-1:2006	Ergonomics of the thermal environment - Part 1
IEC 60974-1:2012 ⁱ	Arc welding equipment - Part 1: Welding power sources
IEC 60974-10:2014 ⁱ	Arc welding equipment - Part 10: EMC requirements
ISO 14644-1:2015 ⁱⁱ	Classification of air cleanliness
IEC 60529:1989 + A2:2013	Degrees of protection provided by enclosures (IP code)

ⁱ Only valid for arc welding robots. Replaces IEC 61000-6-4 for arc welding robots.

ⁱⁱ Only robots with protection Clean Room.

1 Description

1.3.1 Introduction to installation

1.3 Installation

1.3.1 Introduction to installation

General

Depending on robot version an end effector of max weight 1 to 8 kg including payload, can be mounted on the robot mounting flange. See [Load diagrams on page 24](#). Other equipment, such as a hose, can be mounted on the upper and lower arm, max weight 300g/m. See [Hose set mounted on the manipulator arms on page 32](#).

1.3.2 Operating requirements

Protection standards

Description	Protection standard IEC529
Standard	IP54
Wash Down	IP67
Stainless Washdown	IP69K
Clean Room, Stainless Clean Room	IP54

Clean room standards

Description	Protection standard DIN ISO 14644
Standard	Class 7
Clean Room	Class 5
Stainless Clean Room	Class 5

Explosive environments

The robot must not be located or operated in an explosive environment.

Ambient temperature

Description	Standard/Option	Temperature
Manipulator during operation	Standard	0 °C ⁱ (+32 °F) to +45 °C (+113 °F)
For the controller	Standard/Option	<i>Product specification - Controller IRC5 or Product specification - Product.Product-Name</i>
Complete robot during transportation and storage	Standard	-25 °C (-13 °F) to +55 °C (+131 °F)

ⁱ At low environmental temperature < 10° C is, as with any other machine, a warm-up phase recommended to be run with the robot. Below 5° C this warm-up phase is mandatory. Otherwise there is a risk that the robot stops or run with lower performance due to temperature dependent oil- and grease viscosity.

Relative humidity

Description	Relative humidity
Complete robot during transportation and storage	Max. 95% at constant temperature
Complete robot during operation	Max. 95% at constant temperature

1 Description

1.3.3 Mounting the manipulator

1.3.3 Mounting the manipulator

General

Maximum load in relation to the base coordinate system. See Figure below.

Robot version IRB 360-1/800, IRB 360-1/1130, IRB 360-1/1600, IRB 360-3/1130

Force N	Max. load in operation
F _x	±330 N
F _y	±260 N
F _z	-1500 ±170 N

Torque Nm	Max. load in operation
M _x	±200 Nm
M _y	±230 Nm
M _z	±100 Nm

Robot version IRB 360-8/1130, IRB 360-6/1600

Force N	Max. load in operation
F _x	±550 N
F _y	±500 N
F _z	-1500 ±460 N

Torque Nm	Max. load in operation
M _x	±380 Nm
M _y	±440 Nm
M _z	±180 Nm

Robot frame is not included in the delivery.

Stiffness of robot frame

The stiffness of the robot frame must be designed to minimize the influence on the dynamic behavior of the robot. It is recommended that a frame with a lowest natural frequency (with the robot mounted in the frame) higher than 17 Hz is used for robot versions IRB 360-1/1130, IRB 360-3/1130, IRB 360-1/1600 and a frame with a lowest natural frequency higher than 40 Hz is used for robot version IRB 360-8/1130, IRB 360-6/1600. TuneServo can be used for adapting the robot tuning to a non-optimal foundation.



Note

The working space is shown in the first figure in [Robot motion on page 37](#).

Continues on next page

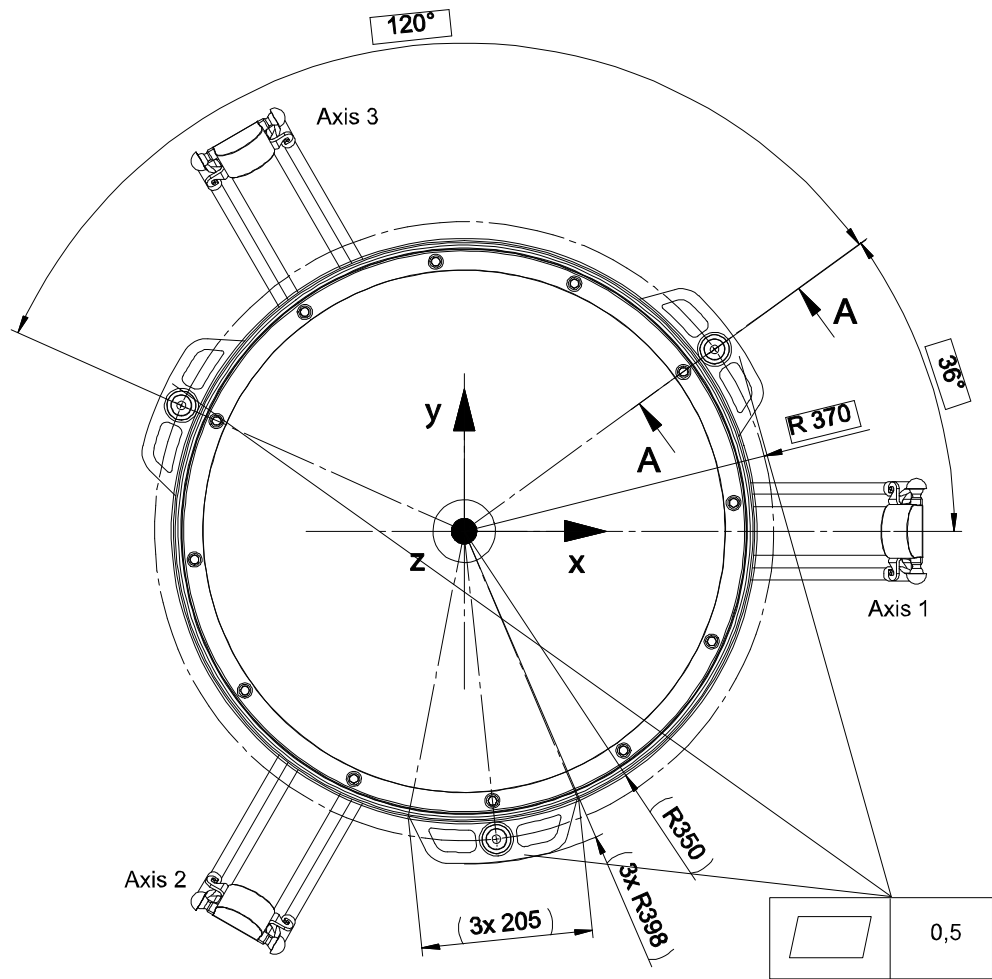

en0900000413

The three support points of the manipulator base box shall be mounted against three flat surfaces within the specification above. Shims is used if necessary.

Continues on next page

1 Description

1.3.3 Mounting the manipulator

Continued

Fastening the robot

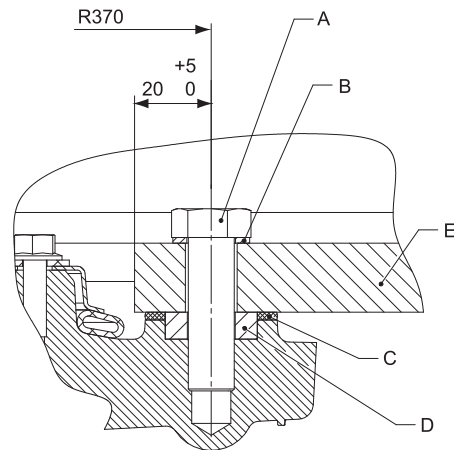
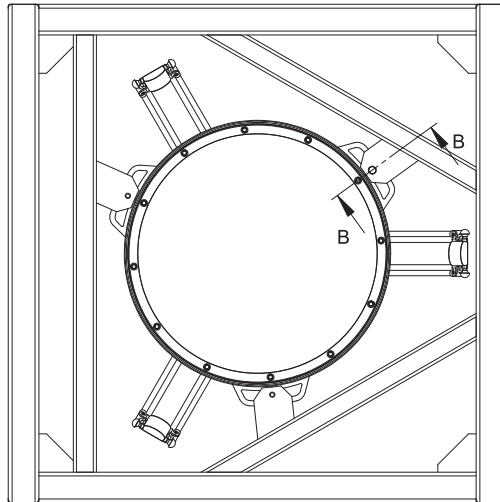

B - B

xx0900000414

Position	Description
A	M12 screw
B	Bonded seal washer, rubber/metal, if not a waterproof joint is required a plain washer can be used
C	Washer, EPDM-rubber, compressed 50%, If no need for waterproof joint is required you can disregard the rubber washer.
D	Spacer, metal
E	Robot frame

Continues on next page

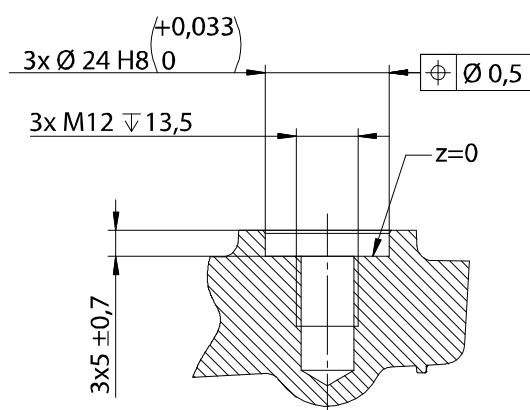

xx0900000415

Recommended screws for fastening the robot to the frame	M12 x (50) 8.8 screw with yield strength 640 N/mm ² or M12 x (50) screw A2-70 with yield strength 450N/mm ² The length of the screws depend on the design of the robot frame.
Torque value	70 Nm

Detection of collisions

The IRB 360 has a basic feature that can detect a collision. This is a system that detects divergence between calculated and actual motor torques. The controller can also stop the robot if load parameters are defined incorrectly, due to that the moment of the torque deviates from the calculated. An advanced option that includes the possibility to manually setting parameters is called *Collision Detection*. For more detailed information see *Application manual - Controller software IRC5* or *Application manual - Controller software OmniCore*.

Fastener quality

When fitting tools on the tool flange, only use screws with quality 12.9. For other equipment use suitable screws and tightening torque for your application.

1 Description

1.4.1 Introduction to load diagrams

1.4 Load diagrams

1.4.1 Introduction to load diagrams

General



WARNING

It is very important to always define correct actual load data and correct payload of the robot. Incorrect definitions of load data can result in overloading of the robot.

If incorrect load data is used, and/or if loads outside the load diagram are used, the following parts can be damaged due to overload:

- motors
- gearboxes
- mechanical structure



WARNING

Robots running with incorrect load data and/or with loads outside the load diagram, will not be covered by robot warranty.

1.4.2 Load diagrams



Note

The weight permitted for loads includes grippers etc.
 The data types `loaddata` and `tooldata` with moment of inertia must be used!

IRB360-1/1130, IRB 360-1/1600 and IRB 360-1/800

Loads 0.1 kg, 0.5 kg and 1.0 kg:

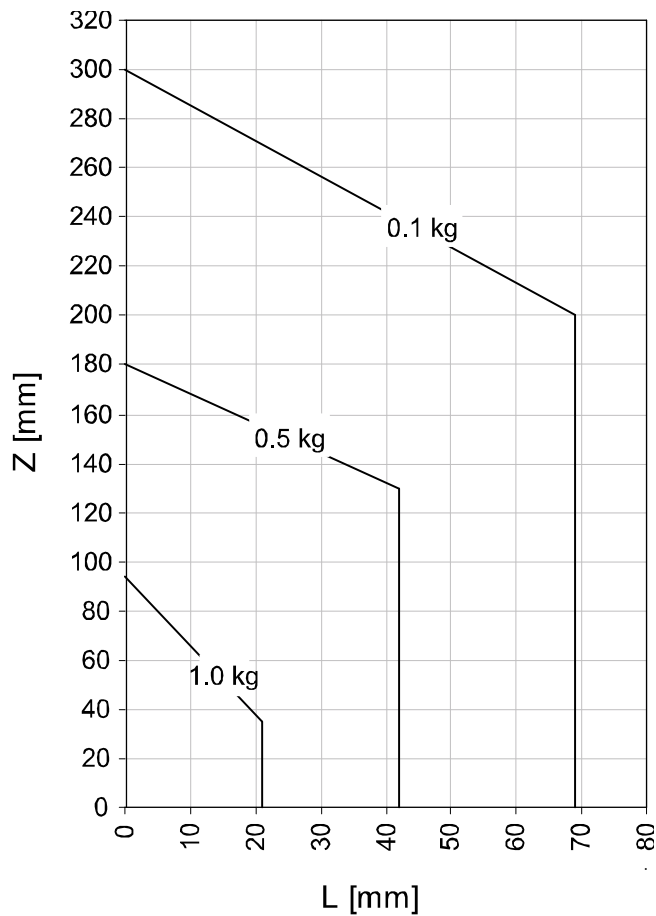

xx0900000416

	Description
Z	See the above diagram and the coordinate system in <i>Product specification - Controller IRC5</i> or <i>Product specification - Product.ProductName</i> .
L	Distance in X-Y plane from Z-axis to the mass center of gravity of the load.
tooldata	Weight of the gripper (kg). The center of gravity of the gripper (mm). The moment of inertia of the gripper (kgm ²). No value or wrong value may damage the robot. For more information see <i>Technical reference manual - RAPID Instructions, Functions and Data types</i>

Continues on next page

1 Description

1.4.2 Load diagrams

Continued

	Description
loaddata	<p>Weight of the product (kg).</p> <p>The center of gravity of the product (mm).</p> <p>The moment of inertia of the product (kgm^2).</p> <p>No value or wrong value may damage the robot.</p> <p>For more information see <i>Technical reference manual - RAPID Instructions, Functions and Data types</i></p>
	<p>For large off-sets in z-direction some combinations of J_o and movement of robot requires use of RAPID commands <code>AccSet</code> and/or <code>TuneServo</code> to minimize vibration of tool. This applies for limited inherent gripper stiffness and the backlash of the picked load, for example a shaking bag.</p> <p> Note</p> <p>Best possible performance of the IRB 360 is achieved when the gripper's center of gravity is close to axis 4 ($L=0$ mm in load diagram).</p> <p>J_o=own moment of inertia of the total handle weight.</p>

IRB360-3/1130

Load 1.0 kg - 3.0 kg

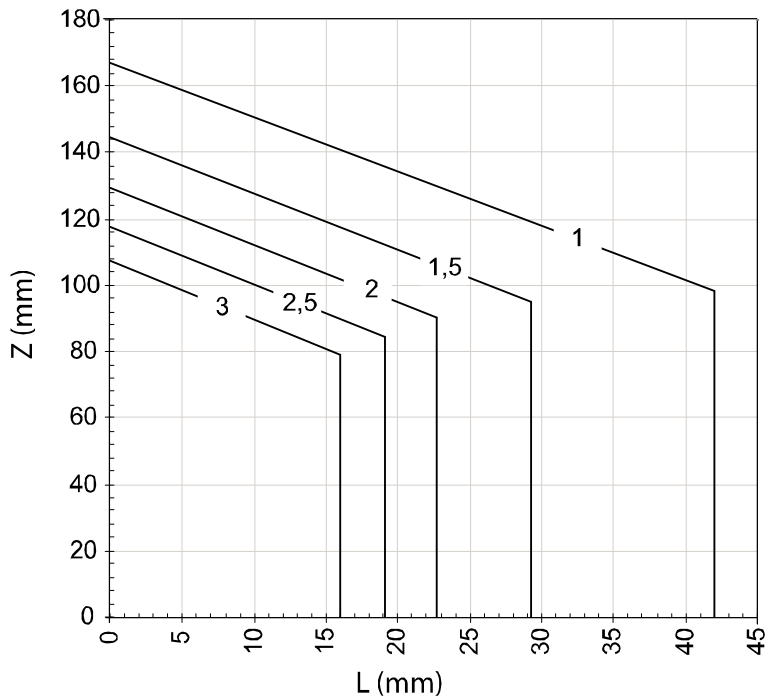

xx0900000419

Load diagram above is valid for $J_{o_{zz}}$ from 0 - 0.0212 kgm^2 .

	Description
Z	See the above diagram and the coordinate system in <i>Product specification - Controller IRC5</i> or <i>Product specification - Product.ProductName</i> .
L	Distance in X-Y plane from Z-axis to the mass center of gravity of the load.

Continues on next page

	Description
tooldata	<p>Weight of the gripper (kg).</p> <p>The center of gravity of the gripper (mm).</p> <p>The moment of inertia of the gripper (kgm^2).</p> <p>No value or wrong value may damage the robot.</p> <p>For more information see <i>Technical reference manual - RAPID Instructions, Functions and Data types</i></p>
loaddata	<p>Weight of the product (kg).</p> <p>The center of gravity of the product (mm).</p> <p>The moment of inertia of the product (kgm^2).</p> <p>No value or wrong value may damage the robot.</p> <p>For more information see <i>Technical reference manual - RAPID Instructions, Functions and Data types</i></p>
	<p>Max. allowed mass moments of inertia is $J_{o_{zz}} = 0.055 \text{ kgm}^2$.</p> <p>For increasing values of $J_{o_{zz}}$ the allowed L-offset of the center of gravity decreases linearly from the values in load diagrams down to zero. For an example of high inertia see diagram on next page.</p> <p>For large off-sets in z-direction some combinations of J_o and movement of robot requires use of RAPID commands <code>AccSet</code> and/or <code>TuneServo</code> to minimize vibration of tool. This applies for limited inherent gripper stiffness and the backlash of the picked load, for example a shaking bag.</p> <p> Note</p> <p>Best possible performance of the IRB 360 is achieved when the gripper's center of gravity is close to axis 4 ($L = 0 \text{ mm}$ in load diagram).</p> <p>J_o=own moment of inertia of the total handle weight.</p>

Figure below shows load diagrams for $J_{o_{zz}} = 0.04 \text{ kgm}^2$.



xx110000102

Continues on next page

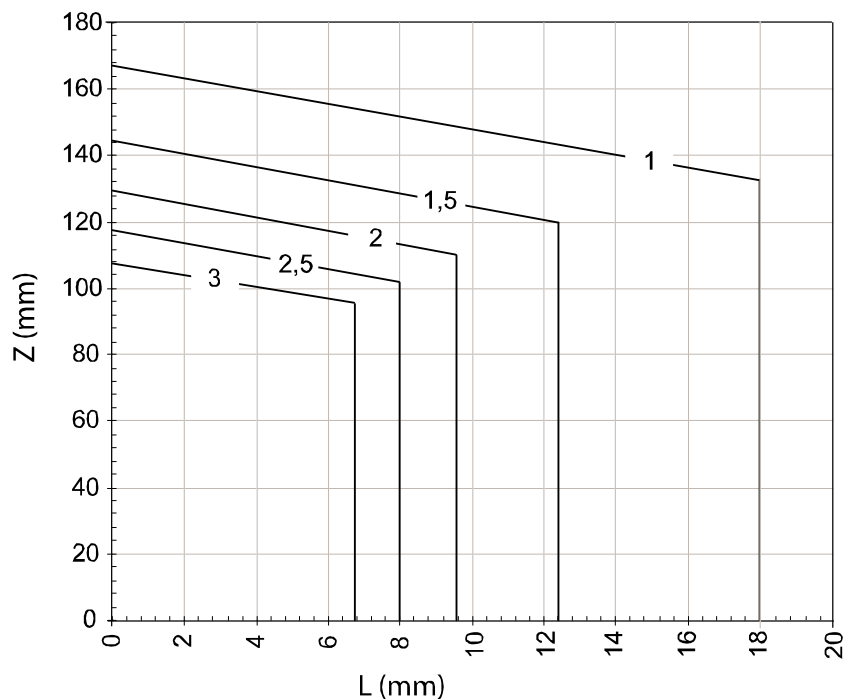
1 Description

1.4.2 Load diagrams

Continued

IRB360-8/1130

Load 1.0 kg - 8.0 kg

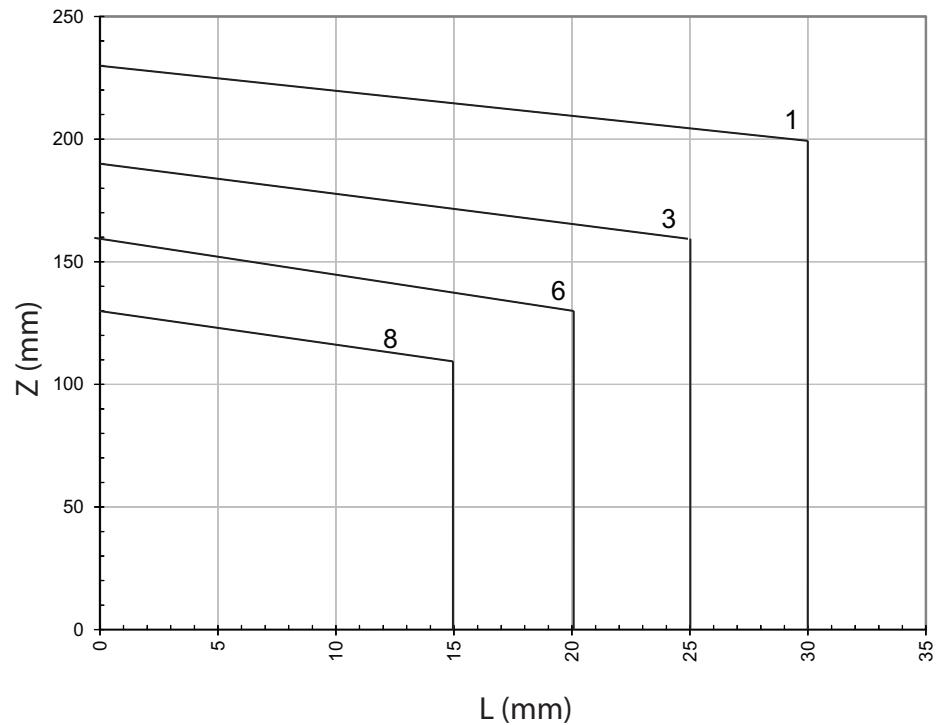

xx1200001391

Load diagram above is valid for $J_{o_{zz}}$ from 0 - 0.1kgm².

	Description
Z	See the above diagram and the coordinate system in <i>Product specification - Controller IRC5</i> or <i>Product specification - Product.ProductName</i> .
L	Distance in X-Y plane from Z-axis to the mass center of gravity of the load.
tooldata	Weight of the gripper (kg). The center of gravity of the gripper (mm). The moment of inertia of the gripper (kgm ²). No value or wrong value may damage the robot. For more information see <i>Technical reference manual - RAPID Instructions, Functions and Data types</i>
loaddata	Weight of the product (kg). The center of gravity of the product (mm). The moment of inertia of the product (kgm ²). No value or wrong value may damage the robot. For more information see <i>Technical reference manual - RAPID Instructions, Functions and Data types</i>

Continues on next page

	Description
	<p>Max. allowed mass moments of inertia is $J_{o\ zz} = 0.15\ \text{kgm}^2$.</p> <p>For large off-sets in z-direction some combinations of J_o and movement of robot requires use of RAPID commands <code>AccSet</code> and/or <code>TuneServo</code> to minimize vibration of tool. This applies for limited inherent gripper stiffness and the backlash of the picked load, for example a shaking bag.</p> <p> Note</p> <p>Best possible performance of the IRB 360 is achieved when the gripper's center of gravity is close to axis 4 ($L = 0\ \text{mm}$ in load diagram).</p> <p>J_o=own moment of inertia of the total handle weight.</p>

IRB360-6/1600

Load 1.0 kg - 6.0 kg

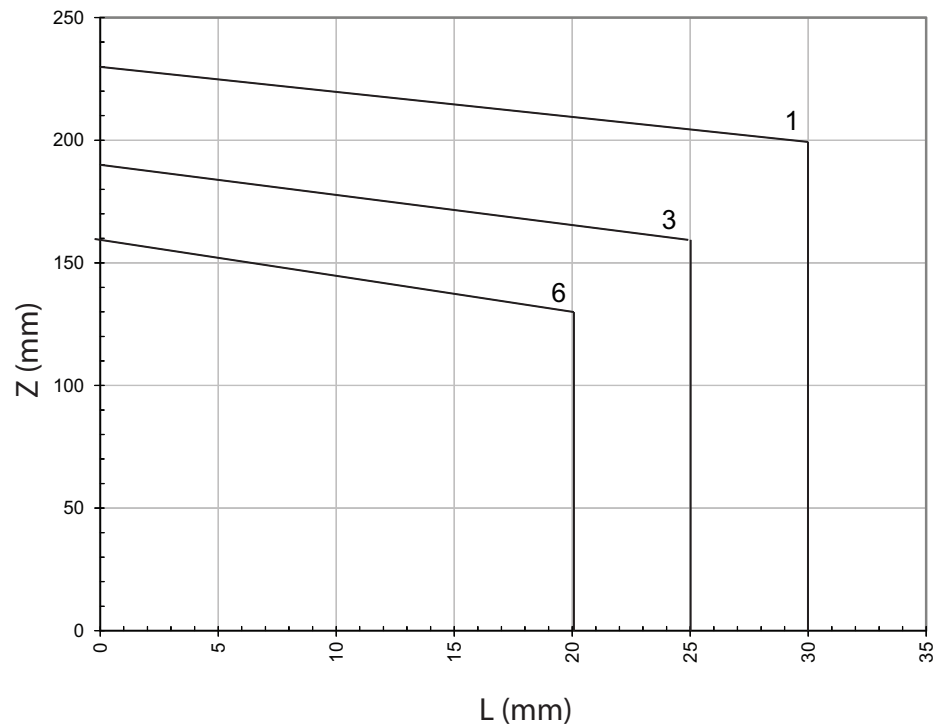

xx130000861

Load diagram above is valid for $J_{o\ zz}$ from 0 - $0.1\ \text{kgm}^2$.

	Description
Z	See the above diagram and the coordinate system in <i>Product specification - Controller IRC5</i> or <i>Product specification - Product.ProductName</i> .
L	Distance in X-Y plane from Z-axis to the mass center of gravity of the load.
tooldata	<p>Weight of the gripper (kg).</p> <p>The center of gravity of the gripper (mm).</p> <p>The moment of inertia of the gripper (kgm^2).</p> <p>No value or wrong value may damage the robot.</p> <p>For more information see <i>Technical reference manual - RAPID Instructions, Functions and Data types</i></p>

Continues on next page

1 Description

1.4.2 Load diagrams

Continued

	Description
loaddata	<p>Weight of the product (kg).</p> <p>The center of gravity of the product (mm).</p> <p>The moment of inertia of the product (kgm^2).</p> <p>No value or wrong value may damage the robot.</p> <p>For more information see <i>Technical reference manual - RAPID Instructions, Functions and Data types</i></p>
	<p>Max. allowed mass moments of inertia is $J_{o_{zz}} = 0.15 \text{ kgm}^2$.</p> <p>For large off-sets in z-direction some combinations of J_o and movement of robot requires use of RAPID commands <code>AccSet</code> and/or <code>TuneServo</code> to minimize vibration of tool. This applies for limited inherent gripper stiffness and the backlash of the picked load, for example a shaking bag.</p> <p> Note</p> <p>Best possible performance of the IRB 360 is achieved when the gripper's center of gravity is close to axis 4 ($L = 0 \text{ mm}$ in load diagram).</p> <p>J_o=own moment of inertia of the total handle weight.</p>

Extra equipment mounted on the manipulator arms

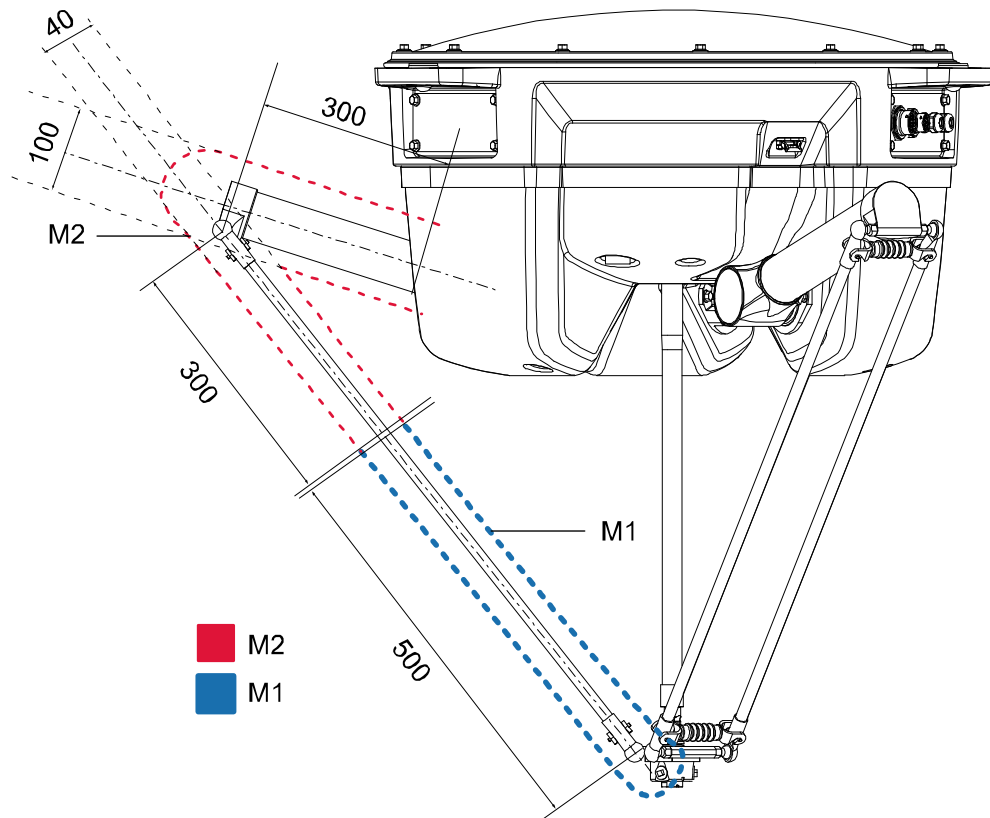

xx0900000420

M1	Limitation lines for center of gravity for M1
M2	Limitation lines for center of gravity for M2

Continues on next page

The robot is tuned for the Vacuum system or medium sized hose (options). If one of these options is used no extra load should be defined. If neither the vacuum system nor the medium sized hose is chosen:

- and both M1 and M2 are less than 175 g each, the robot can run with full performance and no extra load should be defined.
- and M1 is more than 175 g, an extra load should be defined in the load definition. The extra load should be M1-175 g. Maximum extra load allowed is 175 g (M1 max = 350g).
- and M2 is more than 175 g, an extra load should be defined in the load definition. The extra load should be M2-175 g. Maximum extra load allowed is 175 g (M2 max = 350 g).
- The extra load should be defined in TCP 0

1 Description

1.4.3 Hose set mounted on the manipulator arms

1.4.3 Hose set mounted on the manipulator arms

General

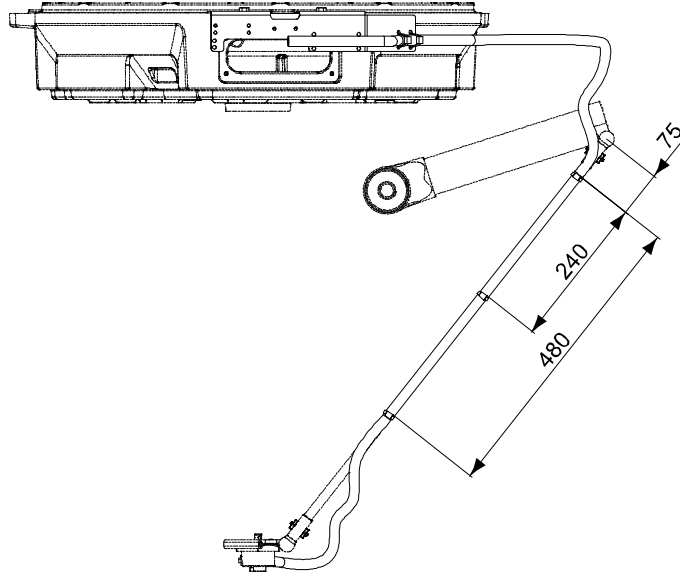

xx0900000422

1.4.4 Mechanical interface

IRB 360-1/1130, IRB 360-3/1130, IRB 360-1/1600

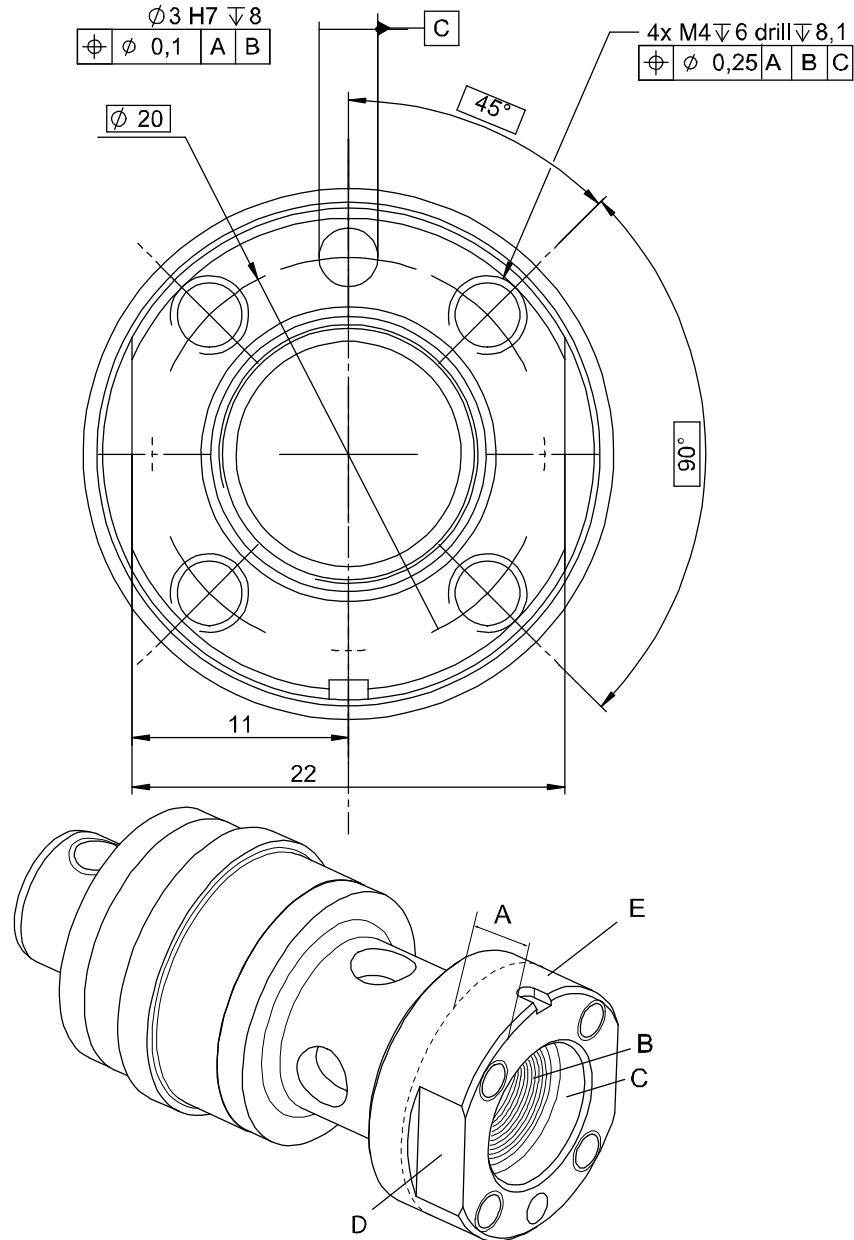

xx070000471

Position	Description
A	Free space, depth 6 mm
B	R1/4"
C	Ø 14 H8 depth 4 mm
D	Key grip = width 22 mm height 5,5 mm
E	Ø 25 h8 depth 6 mm

Continues on next page

1 Description

1.4.4 Mechanical interface

Continued

IRB 360-8/1130, IRB 360-6/1600

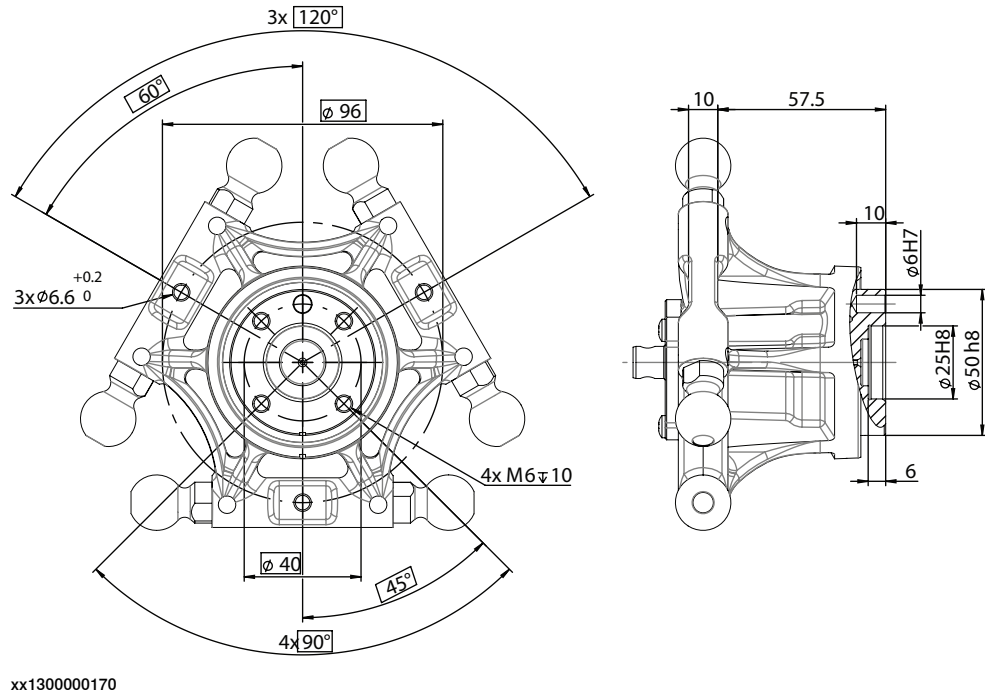

Continues on next page

1 Description

1.5.1 Introduction to maintenance and trouble shooting

1.5 Maintenance and troubleshooting

1.5.1 Introduction to maintenance and trouble shooting

General

The robot requires only minimum maintenance during operation. It has been designed to make it as easy to service as possible:

- Maintenance-free AC motors are used.
- Oil is used for the gear boxes.
- All cabling is fixed, no movements. In the unlikely event of a failure, its modular design makes it easy to change.

Maintenance

The maintenance intervals depend on the use of the robot, the required maintenance activities also depends on selected options. For detailed information on maintenance procedures, see *Product manual - IRB 360*.

1.6 Robot motion

1.6.1 Introduction to robot motion

General



Note

The extreme position of the robot arm is shown in [Extreme position on page 38](#).

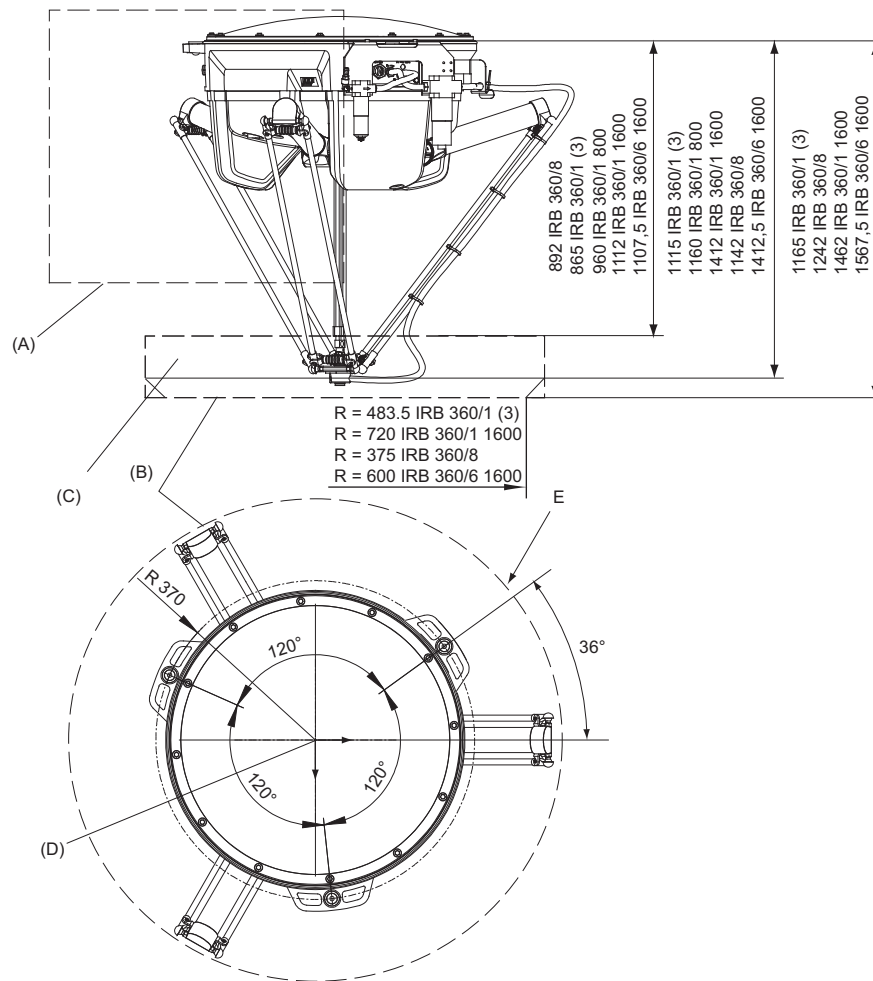

xx090000426

Position	Description
A	Extreme position, see Extreme position on page 38 .
B	Maximum working space inside cylinder. Working space can be reduced in x-y-z coordinates.
C	Marked area = actual working area
D	Base coordinate system
E	Radius 565 mm for IRB 360-1(3, 8)/1130, 400 for IRB 360-1/800 and 800 for IRB 360-1(6)/1600

Continues on next page

1 Description

1.6.1 Introduction to robot motion

Continued

Extreme position

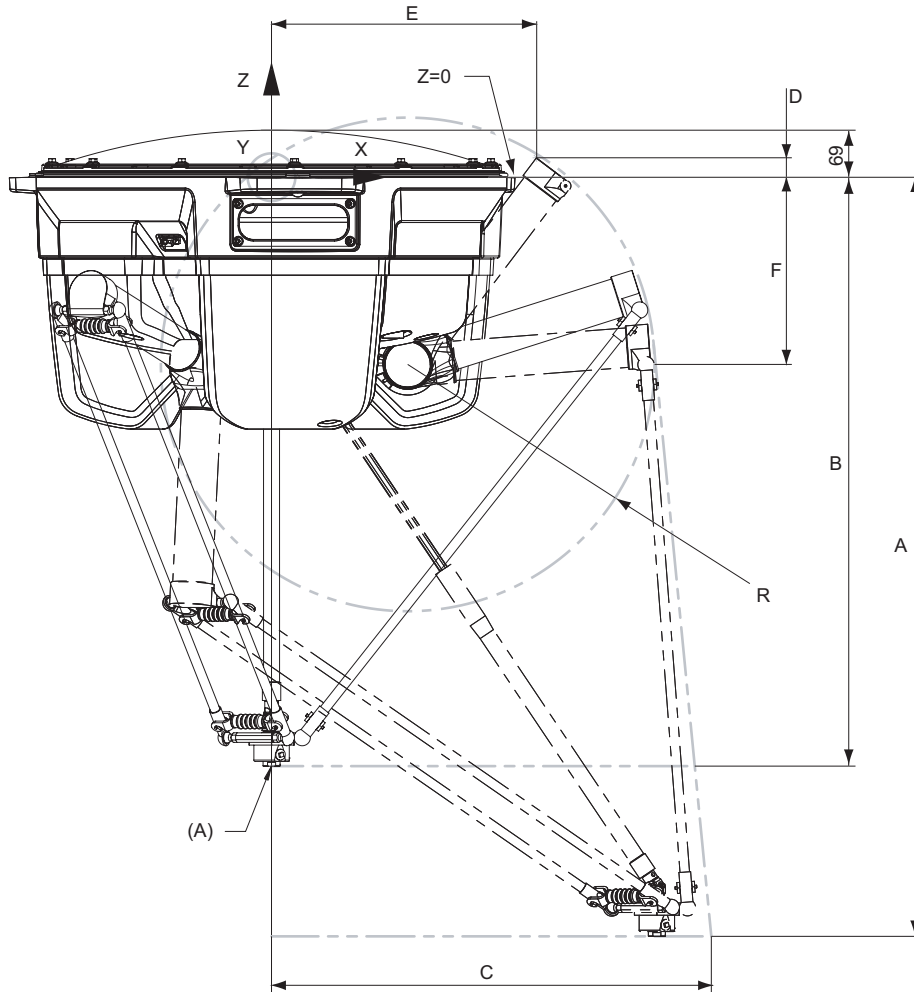

xx0900000427

Position	Description
A	TCP (this position $x=0, y=0, z=865$) TCP (this position $x=0, y=0, z=892$) Valid for IRB 360-8/1130

	A	B	C	D	E	F	R
IRB 360-1/800	1160	960	480	-	-	275	251
IRB 360-1(3)/1130	1115	865	646	28.5	389.5	275	366
IRB 360-1/1600	1412	1112	880	95	438	275	447
IRB 360-8/1130	1142	892	650	28.5	389.5	275	366
IRB 360-6/1600	1412.5	1107.5	883	148.3	478.9	275	515

1.6.2 Performance according to ISO 9283

General

At rated load and 0.8 m/s velocity on ISO test plane with all four robot axes in motion, with different payload. Values in the table below are the average result of measurements on a small number of robots. The result may differ depending on where in the working range the robot is positioning, velocity, arm configuration, from which direction the position is approached, the load direction of the arm system. Backlashes in gearboxes also affect the result.

The figures for AP, RP, AT and RT are measured according to figure below.

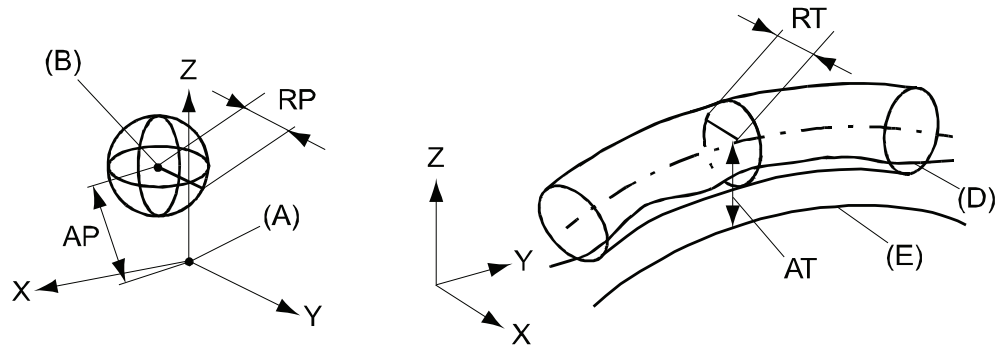

xx080000424

Position	Description	Position	Description
A	Programmed position	E	Programmed path
B	Mean position at program execution	D	Actual path at program execution
AP	Mean distance from programmed position	AT	Max deviation from E to average path
RP	Tolerance of position B at repeated positioning	RT	Tolerance of the path at repeated program execution

IRB 360-1/1130, IRB 360-3/1130 and IRB 360-8/1130	At 0.1 kg	At 1.0 kg	At 3.0 kg	At 8.0 kg
Pose accuracy, AP (mm)	0.01	0.04	0.10	0.04
Pose repeatability, RP (mm)	0.10	0.09	0.06	0.07
Pose stabilization time, Pst (s) within 0.2 mm of the position	ⁱ	0.03	0.05	0.05
Path accuracy, AT (mm)	0.51	0.52	1.00	2.32
Path repeatability, RT (mm)	0.30	0.21	0.14	0.10

ⁱ Data not yet available.

IRB 360-1/800	At 1.0 kg
Pose accuracy, AP (mm)	0.07
Pose repeatability, RP (mm)	0.04
Pose stabilization time, Pst (s)	0.03
Path accuracy, AT (mm)	0.22

Continues on next page

1 Description

1.6.2 Performance according to ISO 9283

Continued

IRB 360-1/800	At 1.0 kg	
Path repeatability, RT (mm)	0.15	

IRB 360-1(6)/1600	At 1.0 kg	At 6.0 kg
Pose accuracy, AP (mm)	0.04	0.01
Pose repeatability, RP (mm)	0.03	0.03
Pose stabilization time, Pst (s)	0.08	0.38
Path accuracy, AT (mm)	0.42	1.91
Path repeatability, RT (mm)	0.33	0.13

Backlash axis 4

Protection class	Value
Standard	0.8°
WashDown	1.0°
Stainless Wash Down	0.8°

Velocity

Direction	Description
x, y, z	10 m/s
θ	2880 °/s

1.6.3 Acceleration

General

Direction	IRB 360-1/800	IRB 360-1/1130	IRB 360-3/1130	IRB 360-8/1130	IRB 360-1/1600
x, y, z	150 m/s ²	150 m/s ²	100 m/s ²	100 m/s ²	i rad/s ²
θ	1200 rad/s ²	1200 rad/s ²	1200 rad/s ²	1200 rad/s ²	i rad/s ²

ⁱ Data not yet available.

Direction	IRB 360-6/1600
x, y, z	100 m/s ²
θ	1200 rad/s ²

1 Description

1.7.1 Introduction to typical cycle times

1.7 Typical cycle times

1.7.1 Introduction to typical cycle times

General

Both cycles incorporate an air activation time of 35 ms for picking and 35 ms for placing. Air activation takes place during the cycle time.

Description of typical cycles
Cycle 1 is a 25 - 305 - 25 movement, with 90 degrees rotation of axis 4.
Cycle 2 is a 90 - 400 - 90 movement, with 90 degrees rotation of axis 4.

Approximate cycle times

Performance (ppm= pick per minute) in the table below is valid for robots with protection class Standard and WashDown.

	IRB 360-1/1130		IRB 360-3/1130		
Payload	0.1 kg	1.0 kg	0.1 kg	1.0 kg	3.0 kg
Cycle 1	200	170	150	150	115
Cycle 2	135	120	100	100	80

	IRB 360-8/1130		
Payload	1.0 kg	4.0 kg	8.0kg
Cycle 1	160	140	100
Cycle 2	110	90	65

	IRB 360-1/800		IRB 360-1/1600	
Payload	0.1 kg	1.0 kg	0.1 kg	1.0 kg
Cycle 1	180	155	170	150
Cycle 2	120	115	120	110

	IRB 360-6/1600		
Payload	1.0 kg	3.0 kg	6.0kg
Cycle 1	140	125	100
Cycle 2	105	95	75

Robots with protection class Stainless WashDown typically have 90-95% of the performance valid for the robots with protection class Standard or WashDown.

1-phase power supply

No noticeable reduction in cycle time has been observed for typical pick and place cycles (25/305/25) for an IRB 360-3/1130 with 3 kg payload with 220 V and default settings. To test the cycle time RobotStudio can be used. For detailed information see the system parameter *Mains tolerance min*, in *Technical reference manual - System parameters*.

2 Specification of variants and options

2.1 Introduction to variants and options

General

The different variants and options for the IRB 360 are described in the following sections. The same option numbers are used here as in the specification form.

The variants and options related to the robot controller are described in the product specification for the controller.

2 Specification of variants and options

2.2 Manipulator

2.2 Manipulator

Variants

Option	Description	Note
435-80	IRB 360-1/1130	
435-81	IRB 360-3/1130	
435-102	IRB 360-1/1600	Not together with options 912-3, 912-2, 174-1 and 887-1
435-120	IRB 360-8/1130	Not together with options 912-3, 912-2, 287-1, and 887-1
435-125	IRB 360-6/1600	Not together with options 912-3, 912-2, 287-1, and 887-1

Protection class

Option	Description	Note
287-1	Clean Room	Class 5

Base box

Option	Protection class	Note
911-1	Standard/WashDown	
911-2	Stainless	

Arm system

Option	Protection class	Note
912-1	Standard	Not together with option 287-1
912-2	WashDown	
912-3	Stainless	

Axis 4

No telescopic shaft and a delta plate without swivel are delivered.

Option	Description	Note
887-1	No axis 4	Not together with option 912-3

Signs on manipulator

Option	Description	Note
334-1	ABB	
334-3	NONE	

Continues on next page

Media outlet

Option	Description
218-5	Signals and power. The customer signal and power are connected directly to the robot base to one FCI 12-pin UT001412SHT (R2.CP) and one FCI 23-pin UT001823SHT (R2.CS) connector. The cable between manipulator and controller is included. The signal and power are connected to one 12-pole screw terminal in the controller.



Note

Only one of the options 218-5 can be selected.

Resolver connection, axis 7

A connector for resolver signals for axis 7 located on the base box.

Option	Description
864-1	On base

Safety lamp

Option	Description
213-1	A safety lamp with an orange fixed light can be mounted on the robot frame. Cable length 400 mm. The lamp is active in MOTORS ON mode.

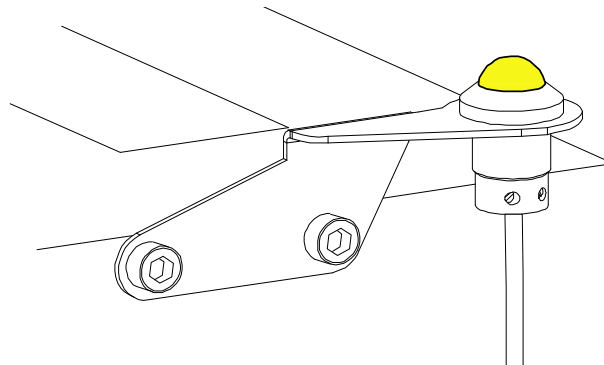

xx0900000429

Continues on next page

2 Specification of variants and options

2.2 Manipulator Continued

Warranty

For the selected period of time, ABB will provide spare parts and labour to repair or replace the non-conforming portion of the equipment without additional charges. During that period, it is required to have a yearly Preventative Maintenance according to ABB manuals to be performed by ABB. If due to customer restrains no data can be analyzed in the ABB Ability service *Condition Monitoring & Diagnostics* for robots with OmniCore controllers, and ABB has to travel to site, travel expenses are not covered. The Extended Warranty period always starts on the day of warranty expiration. Warranty Conditions apply as defined in the Terms & Conditions.



Note

This description above is not applicable for option *Stock warranty* [438-8]

Option	Type	Description
438-1	Standard warranty	Standard warranty is 12 months from <i>Customer Delivery Date</i> or latest 18 months after <i>Factory Shipment Date</i> , whichever occurs first. Warranty terms and conditions apply.
438-2	Standard warranty + 12 months	Standard warranty extended with 12 months from end date of the standard warranty. Warranty terms and conditions apply. Contact Customer Service in case of other requirements.
438-4	Standard warranty + 18 months	Standard warranty extended with 18 months from end date of the standard warranty. Warranty terms and conditions apply. Contact Customer Service in case of other requirements.
438-5	Standard warranty + 24 months	Standard warranty extended with 24 months from end date of the standard warranty. Warranty terms and conditions apply. Contact Customer Service in case of other requirements.
438-6	Standard warranty + 6 months	Standard warranty extended with 6 months from end date of the standard warranty. Warranty terms and conditions apply.
438-7	Standard warranty + 30 months	Standard warranty extended with 30 months from end date of the standard warranty. Warranty terms and conditions apply.
438-8	Stock warranty	<p>Maximum 6 months postponed start of standard warranty, starting from factory shipment date. Note that no claims will be accepted for warranties that occurred before the end of stock warranty. Standard warranty commences automatically after 6 months from <i>Factory Shipment Date</i> or from activation date of standard warranty in WebConfig.</p> <div data-bbox="798 1753 858 1812" data-label="Image"> </div> <div data-bbox="880 1767 946 1796" data-label="Section-Header"> <h4>Note</h4> </div> <div data-bbox="790 1818 1418 1877" data-label="Text"> <p>Special conditions are applicable, see <i>Robotics Warranty Directives</i>.</p> </div>

2.3 Floor cables

Manipulator cable - length

Option	Description
210-1	3 m
210-2	7 m
210-3	15 m
210-4	22 m
210-5	30 m

Connection of parallel communication

Option	Description
94-1	7 m
94-2	15 m
94-4	30 m

2 Specification of variants and options

2.4 Process

2.4 Process

Process module

Option	Type	Description
768-1	Empty cabinet small	See <i>Product specification - Controller IRC5 with FlexPendant</i>
768-2	Empty cabinet large	See <i>Product specification - Controller IRC5 with FlexPendant</i>
715-1	Installation kit	See <i>Product specification - Controller IRC5 with FlexPendant</i>

2.5 User documentation

User documentation

The user documentation describes the robot in detail, including service and safety instructions.



Tip

All documents can be found via myABB Business Portal, www.abb.com/myABB.

This page is intentionally left blank

3 Accessories

3.1 Introduction to accessories

General

There is a range of tools and equipment available, especially designed for the manipulator.

Basic software and software options for robot and PC

For more information, see *Product specification - Controller IRC5* or *Product specification - Product.ProductName* and *Product specification - Controller software IRC5* or *Product specification - Controller software OmniCore*.

PickMaster and vision system

For more information, see *Product specification - PickMaster 3* and *Application manual - PickMaster 3*.

This page is intentionally left blank

Index

A

accessories, 51

D

documentation, 49

I

instructions, 49

M

manuals, 49

O

options, 43

P

product standards, 16

S

safety standards, 16

service instructions, 49

standards, 16

ANSI, 16

CAN, 16

EN IEC, 16

EN ISO, 16

standard warranty, 46

stock warranty, 46

U

user documentation, 49

V

variants, 43

W

warranty, 46



ABB AB

Robotics & Discrete Automation

S-721 68 VÄSTERÅS, Sweden

Telephone +46 (0) 21 344 400

ABB AS

Robotics & Discrete Automation

Nordlysvegen 7, N-4340 BRYNE, Norway

Box 265, N-4349 BRYNE, Norway

Telephone: +47 22 87 2000

ABB Engineering (Shanghai) Ltd.

Robotics & Discrete Automation

No. 4528 Kangxin Highway

PuDong District

SHANGHAI 201319, China

Telephone: +86 21 6105 6666

ABB Inc.

Robotics & Discrete Automation

1250 Brown Road

Auburn Hills, MI 48326

USA

Telephone: +1 248 391 9000

abb.com/robotics